

CZU: 628.932.3:[628.979+628.98]

DOI: <https://doi.org/10.53486/dri2022.16>

THE ENERGY SAVING AND COMFORT RATIO OF SMART LIGHTING

CATRUC ADRIANA ²³

Abstract: *Office buildings, particularly workplaces, are not designed to suit individual indoor comfort needs. Providing comfort in these structures is difficult without sacrificing energy efficiency. This essay includes a thorough literature review addressing comprehensive study subjects on smart lighting, such as problems, goals for implementation, prospects, and technological solutions.*

Key words: *LED bulbs, Fuzzy algorithm, AC power, Machine learning*

JEL CLASSIFICATION: Q4, O3

INTRODUCTION

Labour productivity and human quality of life are significantly influenced by lighting. Acosta et al. (2018) indicate that artificial lighting allows individuals to operate in enclosed spaces like homes, offices, and factories without natural light while extending the workday. Products for the invention of smart lighting are already available. One example of an intelligent lighting solution is an Internet-connected Wi-Fi bulb. This lightbulb links to a smartphone app that can be downloaded and a smart home hub like Amazon Alexa or Google Nest. One may use the app or Amazon Alexa to use voice commands to turn on or off the bulbs. The product also has controls for dimming the lighting and altering the lamp's color (Soheilian et al., 2021). The application provides functions like scheduling the on- and off-times of the lights. Energy conservation is the primary focus of research on intelligent lighting. A significant part of energy usage from lighting systems is the root of the problem. Energy savings are possible with intelligent lighting thanks to several tactical possibilities, one of which is applying smart sources to the lighting control.

LIGHTING CONTROLS

A lighting management system can reduce lighting energy use as well. The designs range from the simplest and most common switches on the board to an advanced computer monitoring system that oversees an entire building. Occupancy and daylight sensing have improved thanks to industry-driven innovation, rendering them even more efficient and inexpensive (Soheilian et al., 2021). The best lighting efficiency in a building is achieved when an energy-efficient lighting management system is used in conjunction with energy-efficient bulbs and luminaires. Additional 20 to 40 percent energy savings are possible with lighting control systems (Acosta et al., 2018). They continuously monitor usage and ambient light levels, only turning on the lights when necessary. With

²³ Ph.D Student, email: catrucadriana@gmail.com
ORCID: 0000-0002-9024-8620

several benefits over fluorescent lamps and incandescent bulbs, LED bulbs are the most excellent option for use in energy-efficient lighting systems.

Nowadays, LED bulb solution has advanced and offers light bulbs that may be utilized in various situations. Additionally, this kind of light bulb has non-dimmable and dimmable alternatives, opening up the possibility for intelligent lighting systems' use (Soheilian et al., 2021). LED bulbs don't contain any mercury and are pretty durable. The light intensity can be changed with an AC light adjuster by dimming the lamp's lightbulb. However, when a variable resistor is utilized to alter the brightness of a lamp, resistance turns some of the energy into waste heat. The schematic view for the intelligent control system for lighting using the component mentioned above is shown in Figures 1, 2, and 3.

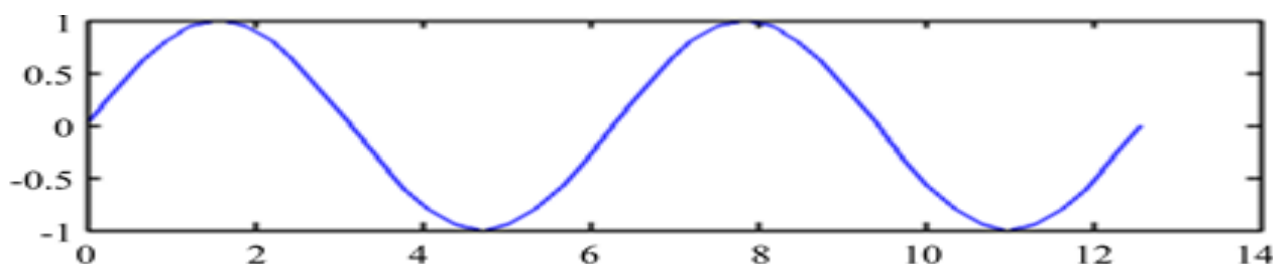

Figure 1: AC Power

Source: (Acosta et al., 2018)

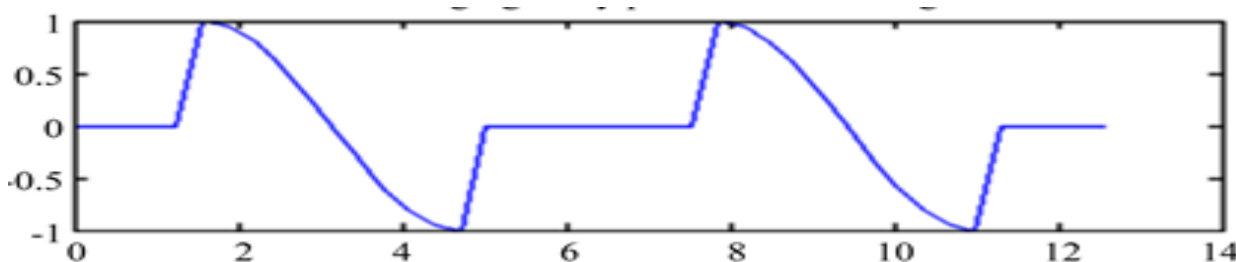

Figure 2: Diminishing Lights by Periodic Switching

Source: (Acosta et al., 2018)

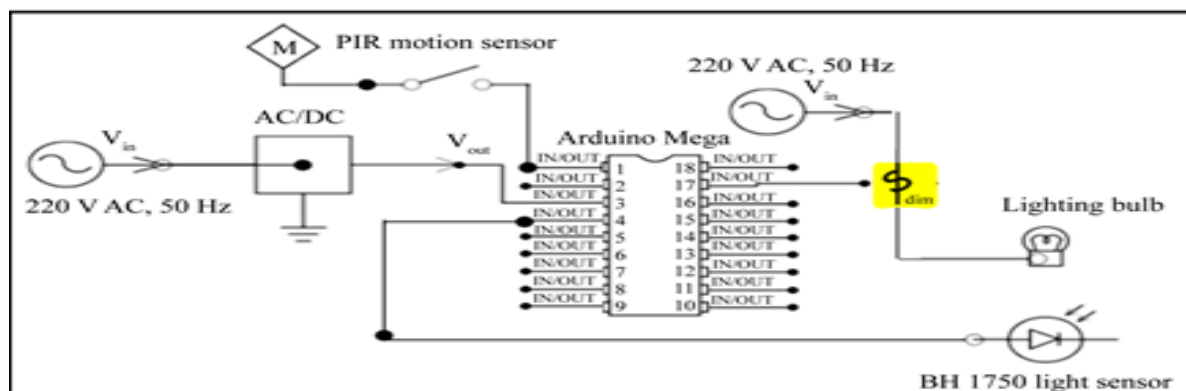

Figure 3: AC Dimmer Smart Lighting Control System

Source: (De Bakker et al., 2018)

FUZZY LOGIC CONTROLLER

Systems for controlling interior lighting now include fuzzy logic controllers. Since they do not necessitate understanding the precise models, these control systems have the benefit of being reliable and relatively easy to develop (De Bakker et al., 2018). It is challenging to rank accurately with precise boundaries when evaluating lighting comfort since it is a subjective measurement of users' pleasure with the quality of the interior environment. According to Lim et al. (2017), fuzzy mathematics is suitable for evaluating lighting comfort. A thorough fuzzy algorithm that considers both natural and smart lighting is recommended to assess users' lighting comfort.

Fig. 4 below depicts the schematic diagram of the suggested control technique that considers lighting comfort. The output of the developed controller using fuzzy logic is the amount of pleasant illumination determined by the illumination level that the light sensors have measured (De Bakker et al., 2018). An algorithm for decisions based on lighting desires and motion signals is presented. The presented algorithm produces the necessary artificial output. The actual lighting output is followed by the real lighting output thanks to a PI closed-loop system.

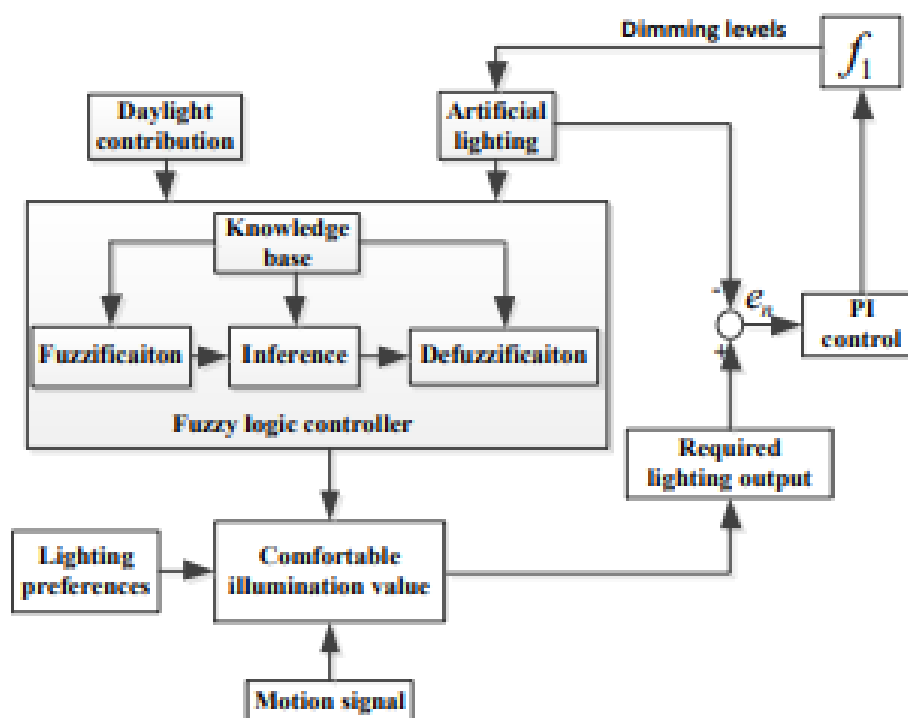

Figure 4: Schematic diagram of a fuzzy logic controller

Source: (Lim et al., 2017)

USER COMFORT ASPECT

De Bakker et al. (2018) suggest that energy efficiency and user comfort are the two main focuses of control systems in smart lighting. User comfort and energy efficiency are the two criteria for integrating smart lighting. Energy efficiency may be measured by evaluating the energy usage of an intelligent lighting system. The formula looks like this:

$$\text{Energy (Wh)} = \text{Power(W)} \times \text{Time(h)} \quad (1)$$

Therefore, the amount of energy utilized increases with the power and duration of usage of the electrical devices. The Unmet Comfort Ratio (UNC), Light Utilization Ratio (LUR), and Light to Comfort Ratio (LCR) can all be used to estimate user comfort. The following is the LUR formula:

$$\text{LUR} = (\text{Time With Lights On}) / (\text{Occupied Time}) \quad (2)$$

According to the formula mentioned, 1 is the ideal LUR value. If it is greater than 1, it is assumed that the lighting is left on longer than is appropriate. In the meantime, it can be assumed that the lamps are on less frequently than they should be if the figure is between 0-1. In contrast, the UNC calculation is as follows:

$$\text{UNC} = (\text{Time in Uncomfortable Condition}) / (\text{Occupied Time}) \quad (3)$$

UNC values range from 0 to 1. The performance of smart lighting improves as it approaches zero. Following is the LCR formula.

$$\text{LCR} = 1 - \sum_{t=1}^n \text{Score}(t) \quad (4)$$

Based on research, it is possible to classify user comfort according to the object in question and its type (Acosta et al., 2018). Depending on the measuring item, the user comfort factor can be separated into control and illumination quality (Acosta et al., 2018).

Assessments centered on control quality examine whether the choices made for intelligent lighting's on/off state conflict with user comfort. The evaluation focused on lighting quality to determine whether or not the light's brightness or hue conflicts with the user's convenience. LUR, which measures the ratio of the times the lights remain on to the amount of time they are used, illustrates a user comfort assessment centered on control quality.

CONCLUSION

Building energy management solutions offer the technical capacity to help users and utilities by reducing energy consumption. These products enable users to reduce or shift loads by providing reminders and monitoring energy usage. They do this by leveraging contextual information like occupancy and daylight availability. The proposed goods available on the market include energy-related and unrelated smart home technologies. With the ability to manage home energy while enhancing security and comfort, such as the ability to lower light loads while driving them vocally, this combination highlights the importance of smart home solutions for consumers. Artificial intelligence and sensing device integration increases energy savings and detection precision. While cutting-edge goods offer these answers, commercialized lighting products lack them compared to other smart home technologies like thermostats, wireless speakers, security cameras, etc. Soon, advanced technologies like artificial intelligence (AI), the Internet of Things (IoT), wireless technology, and networking will change behaviors toward environmentally friendly habits. It will help shift the existing building automation toward innovative and software-defined structures.

REFERENCES

1. Acosta, I., Campano, M. Á., Domínguez-Amarillo, S., & Muñoz, C. (2018). Dynamic daylight metrics for electricity savings in offices: Window size and climate smart lighting management. *Energies*, 11(11), 3143.
2. De Bakker, C., Aarts, M., Kort, H., & Rosemann, A. (2018). The feasibility of highly granular lighting control in open-plan offices: Exploring the comfort and energy saving potential. *Building and Environment*, 142, 427-438.
3. Lim, G. H., Keumala, N., & Ghafar, N. A. (2017). Energy saving potential and visual comfort of task light usage for offices in Malaysia. *Energy and Buildings*, 147, 166-175.
4. Soheilian, M., Fischl, G., & Aries, M. (2021). Smart lighting application for energy saving and user well-being in the residential environment. *Sustainability*, 13(11), 6198.